



# DESIGN AND ANALYSIS OF A TWO SEATER ELECTRIC CAR

**M. Kumaresan**

Professor, Department of Automobile Engineering,  
Karpagam College of Engineering, Tamilnadu, India

**B. Shanthini, S. Rajesh, R. Raja Guru, S.V. Rajesh Kannaa, B. Prasanth**

Final Year, BE Automobile Engineering,  
Karpagam College of Engineering, Tamilnadu, India

## ABSTRACT

*This paper describes the design, analysis and fabrication of a two seater electric car . The problem to be dealt for this thesis work is to design and analysis of the chassis frame using the software. The design modeling was prepared using Solid works and the analysis is carried out using Ansys. The chassis frame is considered as an overhanging beam with supports corresponding to front and rear wheels. The total load acting on the chassis is taken as the sum of the weight of the chassis frame, weight of the persons and the other components. This total load is considered as uniformly distributed load, its corresponding shear force and the bending moment diagram are drawn. bending stress, shear stress and deflection is calculated.*

**Key words:** frame, shear force, bending moment, deflection, design, fabrication

**Cite this Article:** M. Kumaresan, B. Shanthini, S. Rajesh, R. Raja Guru, S.V. Rajesh Kannaa, B. Prasanth, Design and Analysis of a Two Seater Electric Car, *International Journal of Mechanical Engineering and Technology* 9(3), 2018, pp. 94–100.  
<http://www.iaeme.com/IJMET/issues.asp?JType=IJMET&VType=9&IType=3>

## 1. INTRODUCTION

The revolution from traditional gasoline powered vehicles to electric vehicles(EVs) has been a gradual process. Electric vehicles have low maintenance costs. We can achieve significant cost and environmental savings. They require no gasoline and they produce zero emissions.

Riley and George(1) experimentally investigated the several aspects of vehicular frame design, with an emphasis on application to an open wheeled space frame race car chassis as used in formula SAE.

Ravindar pal singh (2010)(2) examined the torsional rigidity and stiffness of formula SAE car.

Guru mahesh and Ajay(2014)(4) describes the design and analysis of a single seater race car chassis frame , considering the important parameters and also calculated the stress distribution under different load condition.

The Objective of the current work is to design and analyse the chassis frame and to fabricate it .

## 2. PROBLEM STATEMENT

One of the important structures of an automobile is the chassis. It is the frame which holds both the body of the car and the various mechanical parts that are bolted onto the chassis. The chassis is also an important component of the overall safety system of an automobile. An important criteria in chassis design is the strength and stiffness. The chassis has to be designed as it has to withstand loads that are over it since it is the load carrying structure. A Tube chassis car will be lighter, stringer and stiffer than a body on frame or unibody car. We have taken circular hollow cross section for making chassis to fabricate the car.

## 3. LOAD ESTIMATION

The total mass of the car components and the persons are listed below

**Table 1**

S.NO	COMPONENTS	MASS(Kg)
1	Chassis	10
2	Battery	9
3	Motor	3
4	Driver + passenger	150
5	Steering	4
6	Suspension	8
7	Tyres	10

TOTAL = 194

## 4. MATERIAL SELECTION

After the estimation of load, the next step in the construction of chassis is the selection of the material. Lightweight and stiffness are the most important properties of the chassis and the stiffness of the complete chassis will be affected by the material stiffness. In addition to this, chassis must also offer some flexibility. After reviewing mechanical properties, availability, cost and other important factors, following material was selected.

**Steel Grade: ASTM A500**

**Table 2**

S.NO	PROPERTIES	VALUES
1	Density	7.85Kg/m <sup>3</sup>
2	Ultimate tensile strength	400MPa
3	Yield tensile strength	315MPa
4	Poisson's ratio	0.28
5	Shear modulus	80GPa
6	Young's modulus	2.016×10 <sup>11</sup> Pa

## 5. SOLID MODELLING

After load approximation and material selection, the next step is the preparation of CAD model of chassis. The geometric modelling of chassis with circular hollow cross section is created using solid works. This 3D model is exported to Ansys for finite element analysis. The three dimensional model of the chassis is shown in fig 1&2.

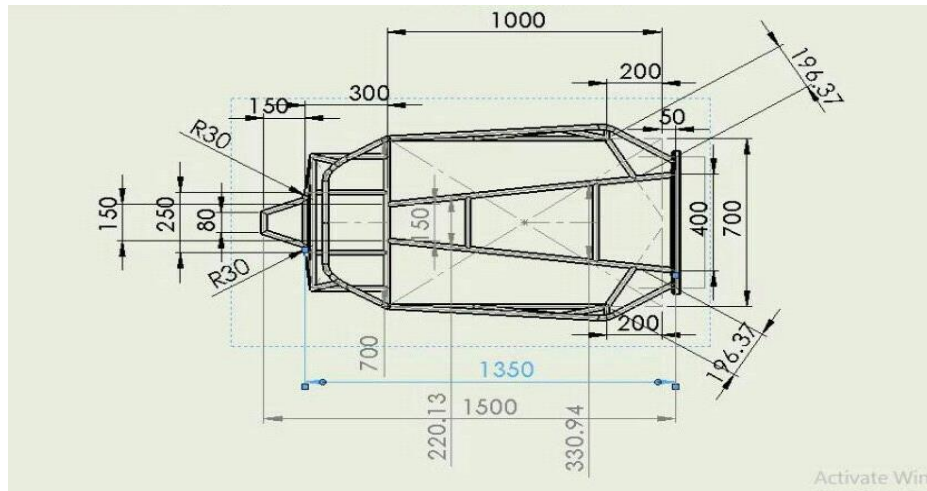

**Figure 1** Dimensions of chassis

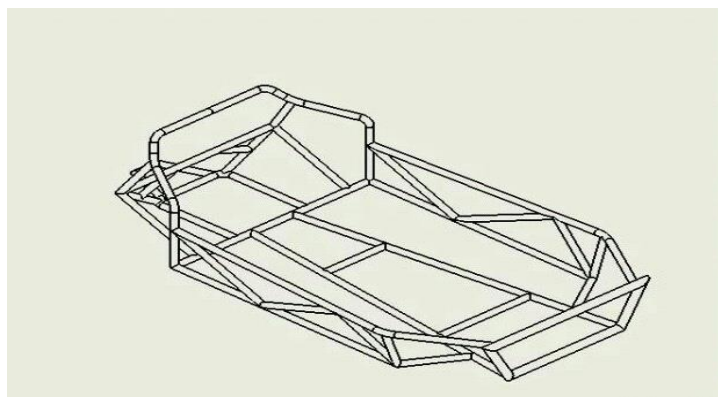

**Figure 2** Model of chassis

## 6. THEORETICAL ANALYSIS

Theoretical Analysis is performed by using the basic concepts from Strength of Materials. The Chassis is considered as an overhanging beam with roller supports corresponding to front and rear wheels. Total load acting on the Chassis is taken as a sum of capacity of the chassis, battery, motor and the persons. This total load is considered as uniformly distributed load acting throughout the span of the beam. Reaction forces, Shear forces and Bending moment are calculated based on the total load.

### Design Calculations for Chassis Frame

Material of the chassis is ASTM A500 Steel ; Weight of the chassis (as calculated)=9.3kgs

Front overhang =150mm      Rear overhang =230mm      Wheel base=1150mm

Modulus of elasticity= $2.1016 \times 10^{11} \text{N/mm}^2$       Poisson's ratio=0.28

Weight of the chassis +motor +Battery +persons (2) =10+3+9+150

$$=172\text{kgs}=1687.32\text{N}$$

Chassis has two beams, so load acting on each=  $172/2=86\text{kgs}=843.6\text{N}=550\text{N/m}(\text{appx})$

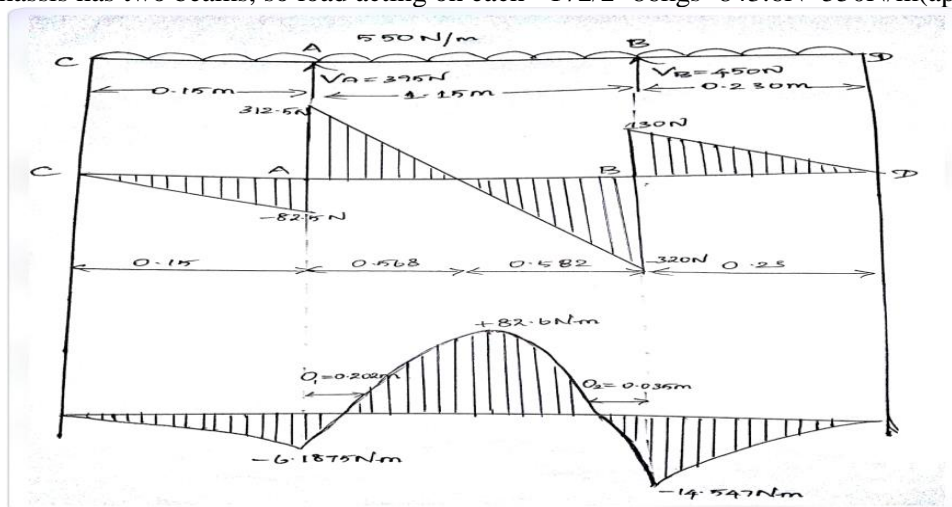

### Calculation for Reactions

Length of the chassis=1530mm      Uniformly distributed load=550N/m

For getting the load at reactions A and B, taking the moment about A

$$V_B \times 1.15 = (1.38 \times 550) \cdot 1.38/2 - (550 \times 0.15) \cdot 0.15/2$$

$$V_B = 517.523/1.15 \quad V_B = 450\text{N} \quad V_A = 845 - 450 = 395\text{N}$$

### Calculation of Shear Force and Bending Moment

*Shear force calculations:*

$$F_C = 0, F_D = 0 \quad F_{AL} = -(0.15 \times 550) = -82.5\text{N} \quad F_{AR} = -82.5 + 395 = 312.5\text{N}$$

$$F_{BL} = 395 - (1.3 \times 550) = -320\text{N} \quad F_{BR} = -320 + 450 = 130\text{N}$$

*Bending moment calculations:*

Equating shear force to zero,

$$-[(0.15+x) \times 550] + 395 = 0$$

$$x = 0.568$$

$$M_C = M_D = 0 \quad M_A = -550 \times (0.15)^2/2 = -6.1875\text{Nm}$$

$$M_B = -550 \times (0.23)^2/2 = -14.547\text{Nm}$$

$M_{\text{max}}$ , maximum bending moment

At 0.568m, BM=0

$$(395 \times 0.568) - 550 \times (0.718)^2/2 = 82.6\text{Nm}$$

Points of contraflexure between A and B =  $V_A \times w l^2/2$

$$= (395x) - 550 \times (0.15+x)^2/2$$

$$= >x^2 - 1.136x + 0.0225 = 0$$

$$X = 1.115\text{m and } 0.0202\text{m}$$

Therefore,  $O_1 = 0.0202\text{m}$  and  $O_2 = 0.0035\text{m}$

### Bending Stress Calculations

$$\text{Area moment of inertia, } I = \pi/64 \times (D^4 - d^4) = \pi/64 \times ((25.4)^4 - (22.4)^4)$$

$$I = 8069.22\text{mm}^4$$

Bending moment equation

$$M/I = \sigma/Y = E/R$$

$M_{max}$ , maximum bending moment

$$= 82.6 \times 10^3 \text{ Nmm}$$

Y, Vertical distance away from the neutral axis = 25.4/2

$$82600/8069.22 = \sigma/12.7$$

Bending stress acting on the beam,  $\sigma = 130.0 \text{ N/mm}^2$

### Shear Stress Calculations

Assume angle of twist =  $1^\circ$

$$\Theta = 1 \times \pi / 180$$

$$= 0.017452 \text{ rad}$$

Distance between two reactions = 1150 mm

$$\begin{aligned} \text{Modulus of rigidity, } G &= 80 \times 10^9 \text{ N/m}^2 \\ &= 80 \times 10^3 \text{ N/mm}^2 \end{aligned}$$

Twisting moment

$$T/J = \tau / r = G\theta / L$$

$$T = rG\theta / L$$

$$= (25.4/2) \times 80 \times 10^3 \times (\pi/180) / 1530$$

Shear stress,  $\tau = 11.584 \text{ N/mm}^2$

According to Von misses Stress theory

$$\begin{aligned} \text{Von misses stress} &= \sqrt{\sigma^2 + 3\tau^2} \\ &= \sqrt{(130)^2 + 3(11.584)^2} = 131.5 \text{ N/mm}^2 \end{aligned}$$

### Deflection

$$\text{Deflection of chassis} = \frac{W \times (b-x)}{24EI} [x(b-x) + b^2 - 2(c^2 + a^2) - \frac{2}{b} [xc^2 + a^2(b-x)]]$$

Where W = Weight of chassis

a = front overhang

b = wheel base

c = rear overhang

x = total length/2

Deflection of chassis = 1.14 mm

## 7. ANALYSIS OF CHASSIS FRAME USING ANSYS

The model of chassis can be directly imported into ANSYS workbench. The model imported to ansys workbench is shown in fig 3.

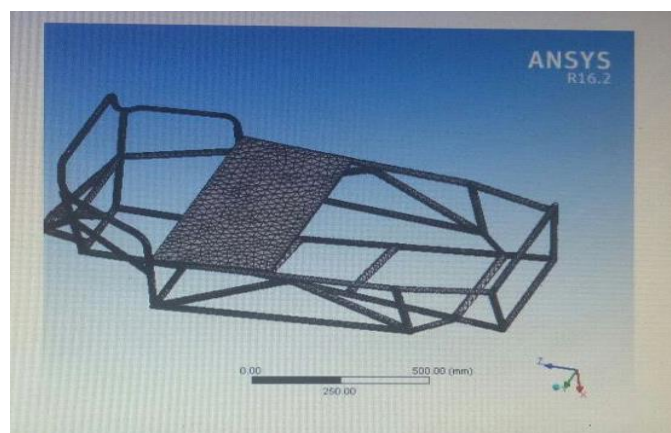

Figure 3 Imported model in Ansys workbench

### Meshing and Boundary Conditions

The meshing is done on the model with 141047 number of nodes and 73231 numbers of tetrahedral elements. The load is assumed as the uniformly distributed. The finite element of the model of the chassis, applied with boundary conditions is shown in fig 4.

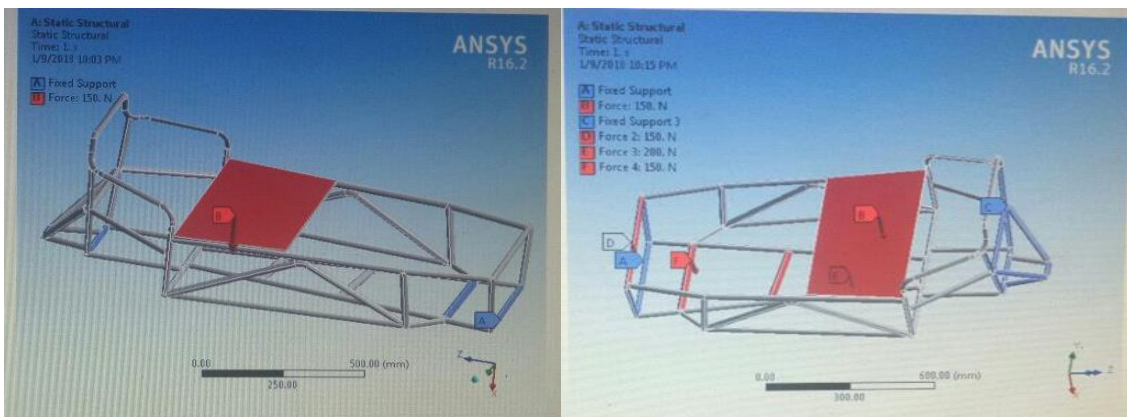

Figure 4

### Structural Analysis of Chassis

A linear finite element analysis of the chassis finite element models under the load was conducted with hollow circular sections with the material ASTM A500 Alloy steel. The contour plots of stress distribution, maximum stress and deformation for the cross section with the material is shown in fig 5,6.

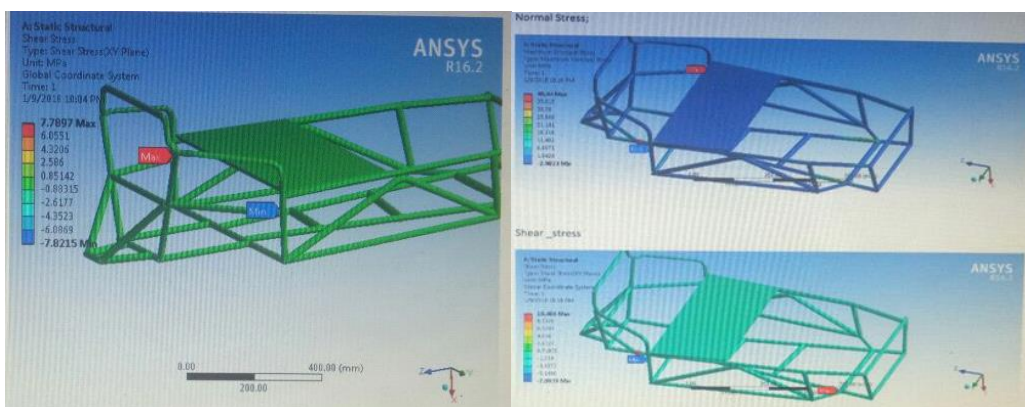

Fig-5

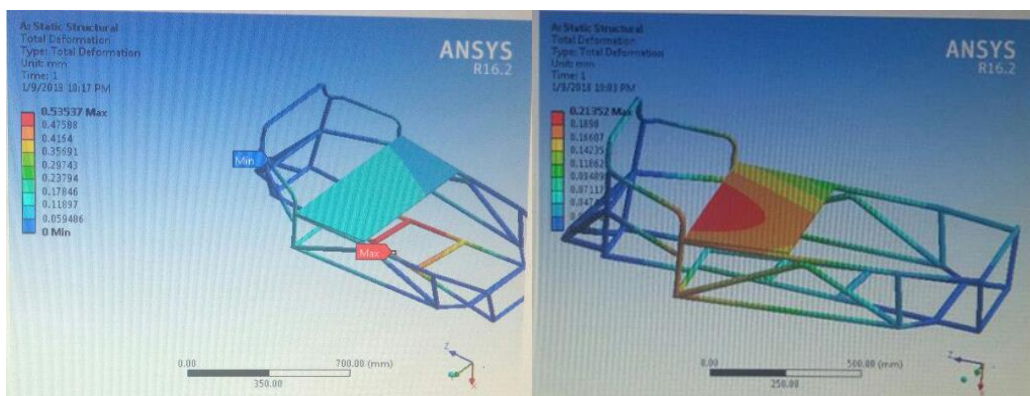

Figure 6

## 8. CONCLUSIONS

In this project I conclude by observing the above results and analyzation that the chassis structure depends on the stresses in that particular frame and also its stiffness. As compared to that of the yield point of the material, the obtained theoretical results above are the well-deserved in order to manufacture a chassis space frame as the result of the stresses are very much lesser. Also the obtained optimum result from the analysis are normal stress=2.9023, shear stress=0.347 and total deformation=0.904mm

## SYMBOLS

$V_A$  - Reaction force at A

$V_B$  - Reaction force at B

$F_{AL}$  - Shear force at A(left)

$F_{AR}$  -Shear force at A(right)

$F_{BL}$  - Shear force at B(left)

$F_{BR}$ - Shear force at B(right)

$F_C, F_D$  - Shear force at C and D respectively

$M_A, M_B, M_C$  and  $M_D$  -Bending Moment at A, B, C and D respectively.

## REFERENCES

- [1] Riley, W.B. george , A.R., 2002, titled with "Design, analysis and testing of formula SAE car chassis", SAE paper 2002-01-3300,motorsports engineering, conference and proceedings.
- [2] Ravindar pal singh, titled with "Structural performance analysis of formula SAE car", December 2010,No.31, 46-61
- [3] 2014 formula SAE rules, SAE international USA
- [4] G.Gurumahesh, D.Lavanya., titled with "Design and analysis of a single seater race car chassis",.vol 2.issue 8,august 2014,pgs 12-23
- [5] A.Harikumar, V.Deepanjali., titled with "Design and analysis of automobile chassis",. volume 5,issue 1,January 2016
- [6] Ahmad Zainal, Nur Rashid ., titled with "Electric car chassis design and analysis using CATIA V5 R19" ,volume11, Issue4 (Jul-Aug 2014), PP 56-59
- [7] Anurag, Amrendra kumar., titled with "Design and analysis of chassis frame" IJRE, Vol 03, No.04, April 2016
- [8] Parishwang Piyush and Ankur Pandey , Use of Vibration Energy For Charging Electric Car , International Journal of Mechanical Engineering and Technology , 7(2), 2016, pp. 59 - 65 .
- [9] Amanana Venkatesh and S. Sivakamasundari, Experimental Study of Concrete Filled Double Skin Tubular Structures In B ending. International Journal of Civil Engineering and Technology , 8(4), 2017, pp. 1815-1823